

HAUPA CABLE GLANDS

- METRIC NYLON GLANDS M12-M63

Cable glands protect electric equipment (for example switches or junction boxes) against mechanical treatment, dust and humidity, while also creating a firm connection between cable and box. Haupa cable glands are available with the IP rating IP68 (dust and waterproof).

Haupa cable glands are available in standard black for metric threads (light grey and PG threads available on special order).

TECHNICAL PROPERTIES:

- Temperature range: - 40°C to + 85°C
- Vibration protection: integrated anti-twist protection for vibration firm assembly
- Fire class: according to UL 94 V-2
- Protection category: IP68
- Material: polyamide 6.6
- Properties: integrated strain relief; easy to install RoHS-conform
- Delivery: completely assembled as shown



haupa®

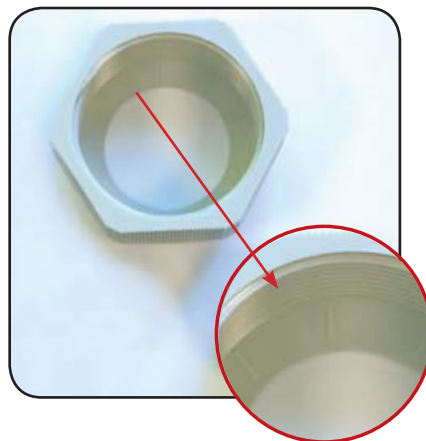

HAUPA NYLON CABLE GLANDS – METRIC

Cable glands IP68, metric (PG on special order), assembled with washer and lock nut

- **MATERIAL:** polyamide 6.6, (gland body: PA 6.6, halogen free, seal: TPR, halogen free, washer: PVC),
- **COLOUR:** black (light grey on special order)
- **TEMPERATURE RANGE:** – 40°C to + 85°C,
- **VIBRATION PROTECTION:** integrated anti- twist protection for vibration- firm assembly,
- **FIRE CLASS:** according to UL 94 V-2,
- **PROTECTION CATEGORY:** IP68,
- **PROPERTIES:** integrated strain relief; easy to install, RoHS- compliant, completely assembled as shown

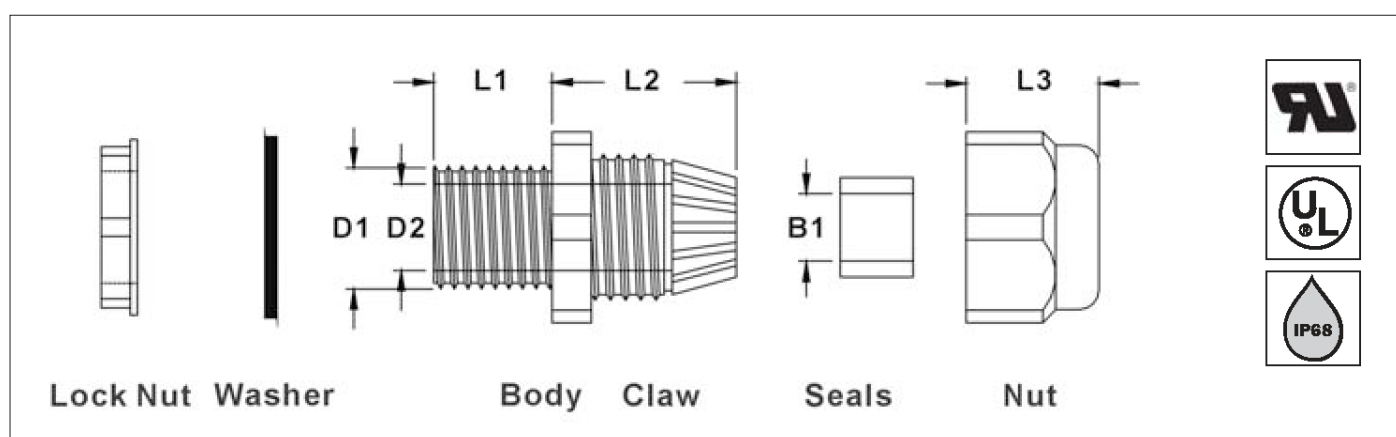

Product #	Cable Range	D1	D2	B1	L1	L2	L3	Washer size	Colour	Weight	Bag	Box
250080	M12	3-6.5	12	8.3	6.9	7.9	19.6	13.6	15	Black	17.9	10 4250
250082	M16	5-10	16	10.9	9.6	15.5	23.4	16.9	22	Black	17.9	10 1700
250088	M20	10-14	20	15	14.8	15	28.5	18.5	27	Black	19.1	10 1190
250090	M25	13-18	25	18.6	18.4	15.2	29.4	22.3	33	Black	18.8	10 680
250092	M32	18-25	32	25	25	14.7	34.5	25.7	42	Black	15.8	10 34
250094	M40	22-32	40	33.7	33.1	18.4	41.7	31.3	54	Black	21.3	5 230
250096	M50	30-38	50	41.9	40	17.8	44.2	31.3	61	Black	16.0	5 160
250098	M63	34-44	61	55	43.2	18.5	44.6	32.7	66	Black	12.5	5 120

Edition: 002 5/16

TransNet New Zealand Ltd Auckland

20 Neilpark Drive
East Tamaki
Auckland
NEW ZEALAND
Ph 0800 442 182
Fax 0800 442 183
PO Box 39 383
Howick, Auckland

Wellington

18 Sydney Street
Petone
Wellington
NEW ZEALAND
Ph 04 576 2530
Fax 04 576 0040
PO Box 39 383
Howick, Auckland

sales@transnet.co.nz

NEW ZEALAND

TransNet Equipment Pty Ltd Perth

Unit 20, 8 Hurley Street
Canning Vale WA 6155
Perth
AUSTRALIA
Ph +61 8 9256 3417
Fax +61 8 9256 3917
PO Box 1439
Canning Vale DC WA 6970

sales@transnetequipment.com

AUSTRALIA

TransNet Tonga Tonga

Small Industries
Ma'ufanga
Tonga
Ph +67 627 939
Fax +67 627 976

PO Box 2932
Nukualofa

transnet@kalianet.to

TONGA